



SEPTEMBER
2025



Roofing Products

A Division of **MACSTEEL**

PRODUCT BROCHURE

ROOFING INNOVATION



Harvey Elite® Midnight Black



Harvey Elite Plus® Burgundy



Harvey Thatch Greystone®



Harvey EcoTile®



Look for the Harveytile Quality Stamp ▶▶



Harvey Roofing Products

Smarter Roofing Starts Here

For over five decades, Harvey Roofing Products has been a trusted name in roofing, delivering innovation, strength, and style to homes and buildings across Southern Africa. We have built a reputation for manufacturing premium lightweight steel and composite roof tiles that combine the timeless beauty of traditional roofing with the advanced performance of modern materials.

Our range includes Harvey Elite, Elite Plus, Thatch and the revolutionary Harvey EcoTile®, offering architects, specifiers, and homeowners roofing solutions that are durable, stylish, and engineered for South Africa's diverse climate. Whether you're building new or re-roofing, Harvey tiles provide exceptional protection against leaks, extreme weather, and fading—ensuring long-lasting peace of mind.

At Harvey Roofing Products, we believe a roof is more than just shelter—it's a statement of quality and a safeguard for your most valuable asset: your home. That's why we are committed to sustainable practices, uncompromising standards, and continuous innovation.

With nationwide availability and a legacy of excellence, Harvey Roofing Products continues to set the standard for roofing that is beautiful, dependable, and built to last.

What Sets Harvey Roof Tiles Apart?

Unmatched Quality you can see and Feel.

At Harvey, quality isn't just a promise – it's built into every tile. We use only the finest materials to craft roof tiles that

are precision-engineered for strength, durability, and lasting protection.

From the moment you see and touch a Harvey tile, you'll recognize the difference – a roofing solution designed to safeguard your home, your family, and everything you value.

BEWARE OF INFERIOR IMITATIONS!

Look for the Harvey Quality Stamp Under Each Tile.

20 Year Warranty

Harvey Roof Tiles has excellent functional benefits, offering a 20 year Product Warranty (Terms & Conditions apply).

Stronger. Smarter. Made to last.



Re-roofing with Harvey Roof Tiles easily transforms a home with no disruption to occupants.

Harvey Roofing Product Range



Harvey Elite



Harvey Elite PLUS



Harvey Thatch

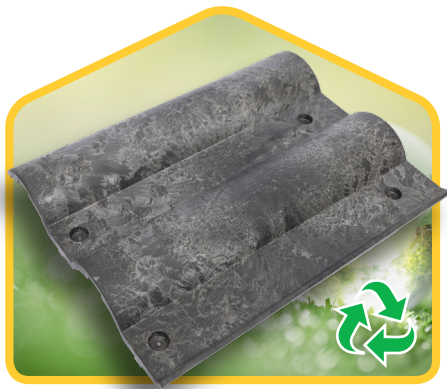

Harvey EcoTile



Harvey Solar Bracket

Bracket Specification

The Harvey Solar bracket is suitable for the application of solar panels and geysers. Manufactured from high tensile steel, there is no need to pierce the Harvey Roof Tile and risk a leaking roof. The Harvey Solar Bracket is easily fitted onto the timber or steel batten. Uniform Wind Uplift: 2Kn/m²

Profiles

Harvey Elite

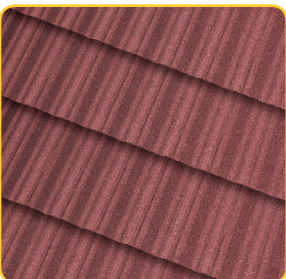

Tile Specification (Approx.)

Overall Length: 1675 mm
 Cover: 1600 mm
 Overall Width: 397 mm
 Substrate Thickness: 0.35mm
 Cover: 369 mm
 Mass per tile: 3.3 kg
 Mass per sq. metre: 5.6 kg
 No. of tiles per sq. metre: 1.69

Harvey Elite Plus

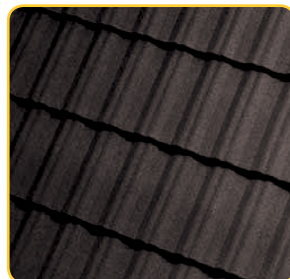

Tile Specification (Approx.)

Overall Length: 1675 mm
 Cover: 1600 mm
 Overall Width: 397 mm
 Substrate Thickness: 0.45mm
 Cover: 369 mm
 Mass per tile: 3.9 kg
 Mass per sq. metre: 6.6 kg
 No. of tiles per sq. metre: 1.69

Harvey Thatch



Tile Specification

Overall Length: 1675 mm
 Cover: 1 625 mm
 Overall Width: 395 mm
 Cover: 350 mm
 Mass per tile: 4.2 kg
 Mass per sq. metre: 6.9 kg
 No. of tiles per sq. metre: 1.76

Double Roman EcoTile



Tile Specification

Overall Length: 420 mm
 Cover: 335 mm
 Overall Width: 324 mm
 Cover: 310 mm
 Mass per tile (ave): 1.6 kg
 Mass per sq. metre: 15.36 kg
 No. of tiles per sq. metre: 9.6

Product Range Standard Colours



Midnight Black

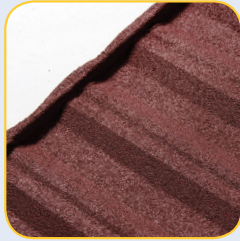

Burgundy



Green



Terracotta

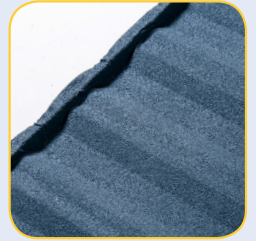

Dark Blue



Midnight Black



Greystone

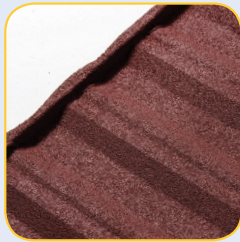

Burgundy



Green

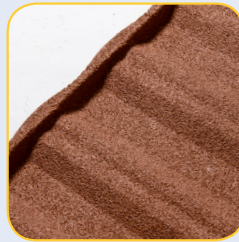

Terracotta

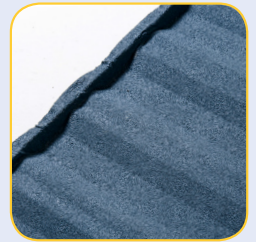

Dark Blue



Thatch Dark



Thatch Light



Thatch Greystone



Thatch
Midnight Black



Marbled Black

The
Affordable
Quality
Guaranteed
Steel Roof Tile



Harvey Elite: Lightweight Strength with Timeless Style.

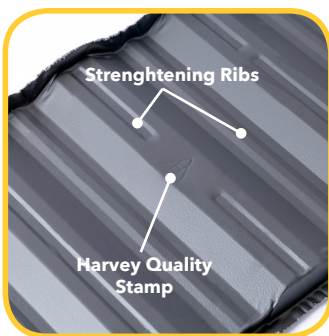

Your home is one of your most significant investments, and a Harvey Roof ensures it's protected. Safeguard your loved ones, cherished possessions, and the value of your home with the trusted quality and elegance of Harvey Elite Roof Tiles.

Lightweight, leakproof and weatherproof, Harvey Elite Roof Tiles not only look good, it reduces long-term maintenance and cost on your roof structure. Harvey Elite's strength lies in the use of high grade materials and unique Strengthening Rib design.

With Harvey Elite, you get more than a roof – you get peace of mind, lasting beauty, and exceptional value.



Super Lightweight

- Lightweight steel-based roof tiles
- Save on roof-structure timber costs
- Ideal for new roof or re-roofing old roofs



Weatherproof

- Gaps are eliminated
- Wind proof
- Hail proof
- Water and leakproof
- Minimised dust ingress
- No water absorption



Low Maintenance

- Avoid the inconvenience of fixing leaks
- Tiles do not need replacement



Attractive

- A range of stunning standard colours
- Double roman design for a unique roof appearance
- Ridge, cap and trim accessories for a professional finish



Unbreakable

- Unbreakable steel substrate
- Bonded stone granules protects against the elements
- No more broken roof tiles even in hailstorms



Solar Compatible

- Fixing brackets available
- A steel drill bit can easily be used for drilling holes for wiring / piping requirements



Easy to Install

- Easily installed on new roofs or over existing roof
- Engineered for effortless overlapping and fixing
- Lightweight for handling and on-site speed



Important

When walking on Harvey Tiles, always wear grippy, soft-soled work footwear. Step sideways along the bottom centre as this is supported by the battens, or try to step on two tiles at once.... It is important that you distribute your weight evenly and keep your centre of gravity. Do not step into the "pan" of the tile.

The
Original
Steel Roof Tile
Since 1967



The original Harveytile with its legendary strength and good looks.

Since 1967, Harvey Elite Roof Tiles have been enhancing homes with proven strength and stylish designs. Combining classic appeal with modern durability, they offer unmatched protection and a fashionable finish to any home. Harvey Elite Plus® features a thicker steel substrate for the most challenging environments, while remaining light in weight to reduce load on roof structures.

Leakproof and weatherproof Harvey Elite Plus Roof Tiles not only look good, they reduce long-term maintenance and cost on your roof structure. Available in a variety of popular colors, Harvey Elite Plus Roof Tiles are built to last—resisting breakage, fading, and leaks, no matter what challenges the weather brings. Choose Harvey for a roof that combines style, strength, and reliability.



Light in weight

- Lightweight steel-based roof tiles
- Save on roof-structure timber costs
- Ideal for new roof or re-roofing old roofs



Low Maintenance

- Avoid the inconvenience of fixing leaks
- Tiles do not need replacement



Unbreakable

- Unbreakable steel substrate
- Bonded stone granules protects against the elements
- No more broken roof tiles even in hailstorms



Solar Compatible

- Fixing brackets available
- A steel drill bit can easily be used for drilling holes for wiring / piping requirements



Weatherproof

- Gaps are eliminated
- Wind proof
- Hail proof
- Water and leakproof
- Minimised dust ingress
- No water absorption



Attractive

- A range of stunning standard colours
- Double roman design for a unique roof appearance
- Ridge, cap and trim accessories for a professional finish



Easy to Install

- Easily installed on new roofs or over existing roof
- Engineered for effortless overlapping and fixing
- Lightweight for handling and on-site speed



Harvey Thatch®

The charm of thatch without the maintenance.

Harvey Thatch solves all the maintenance problems of natural thatch roofs but retains the African look you love. It is installed over a layer of natural thatch so you still enjoy the charm and insulation properties within your home.



Lightning Safe

- Non-combustible and fire resistant
- No need for lightning conductor
- Standard earthing required



Vermin, Bird & Pest Proof

- Water and airtight solution
- No access to the roof for vermin
- No need for unsightly chicken wire



Fade Proof

- Natural, uncoated stone
- Unaffected by the sun's UV rays



Lightweight

- Lightweight steel-based roof tiles
- Save on roof-structure timber costs
- Ideal for new roof or re-roofing old roofs



Naturally Attractive

- A choice of 4 natural stone colours
- Shake Tile design for a thatch roof appearance
- Ridge, cap and trim accessories for a professional finish
- Use of natural stone as grit
- Beware of imitations that use coloured sand prone to fading.



Never Paint

- Natural stone coat
- Never needs painting



Low Maintenance

- Avoid the inconvenience of leaks
- Eliminates the need for thatch combing
- Never re-thatch



Unbreakable

- Unbreakable steel substrate
- Bonded stone granules protects against the elements
- No broken roof tiles



Solar Compatible

- Fixing brackets available



Weatherproof

- Gaps are eliminated
- Wind proof
- Hail resistant
- Water and leakproof
- No dust ingress
- No water absorption



Easy to Install

- Easily installed on new roofs or over an existing roof
- Engineered for effortless overlapping and fixing
- Lightweight for handling and on-site speed



20 Year Warranty

- Excellent functional benefits including a 20 year Product Warranty (Terms & Conditions apply).



Harvey Thatch® Midnight Black



Harvey Thatch® Dark

Re-roofing with Harvey Thatch®



Before



After

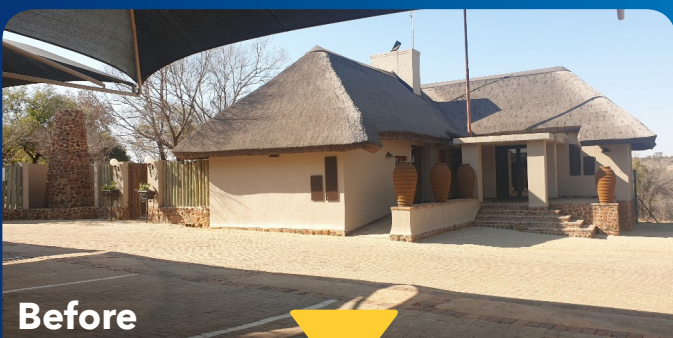

Before



After



CSIR FireLab Test

Superior Fire Resistance

Natural thatch poses a significant fire risk to owners and occupants. Harvey Thatch gives you complete peace of mind as fire risk is reduced to a minimum. Harvey Thatch is certified with an 'A' Fire Rating, the highest roof material fire resistance as tested to SANS 10177-12 standard*.

*When installed to specification

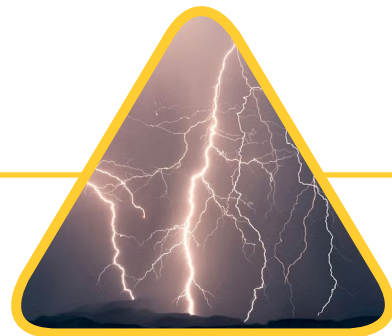

Effects of lightning

Lightning will generally strike the highest object in an area, regardless of the material from which it is made. Harvey Thatch does not create nor attract lightning and if struck, is non-combustible. One does not require a lightning pole, however the roof should be earthed like all metal roofs. All wiring should be insulated.

Harvey Steel-based Tile Accessories



1 Angle Ridge

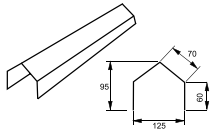

Fixed to double batten at apex
Length: 1720mm (cover 1600mm)
Width: 125mm tapered lengthwise
Height: 95mm
Mass: 2.5kg

2 Angle Ridge End Cap

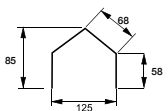

Fixed to end of Angle Ridge
Width: 125mm
Height: 90mm

3 Angle Hip Cap

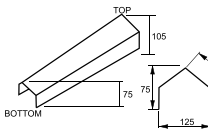

Fixed to double batten at hip battens
Length: 580mm (cover 1 per tile course)
Width: 125mm tapered down to 123mm
Height: 75mm tapered up to 105mm
Mass: 0.8kg

4 Angle Hip End Cap

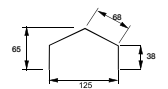

Fixed to end of Angle Hip
Width: 125mm
Height: 70mm

5 Square Ridge (Elite only)

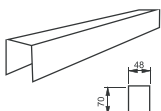

Fixed to double batten at apex
Length: 1720mm (cover 1600mm)
Width: 48mm tapered lengthwise
Height: 70mm
Mass: 1.8kg

6 Square Hip Cap (Elite only)

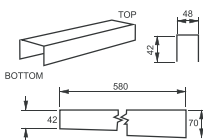

Fixed to single hip batten
Length: 580mm (cover 1 per tile course)
Width: 48mm tapered down to 45mm
Height: 42mm tapered up
Mass: 0.5kg

7 Bargeboard Cover

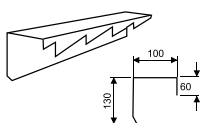

Left and right hand serrated. Fixed to barge boards at gable ends. Sketch shows right handed barge board cover.
Length: 1550mm Height: 130mm
Cover 4 tile courses
Mass: 2.3kg

8 Sidewall Flashing

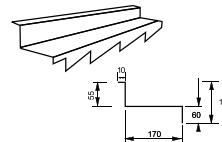

Left and right hand serrated. Sketch shows right handed sidewall.
Length: 1550mm Height: 115mm
Cover 4 tile courses
Width: 170mm Upper Lip: 10mm

9 Cover Flashing

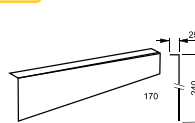

For use at headwall and sidewall flashing as well as for short courses at ridge.
Length: 1720mm Width: 240mm
Upper Lip: 25mm Cover: 1600mm
Mass: 2.5 kg

10 Gable Trim (Elite only)

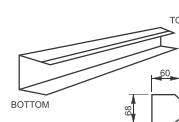

Fixed to gable ends
Length: 1720mm (cover 1600mm)
Width: 60mm
Height: 68mm tapered up
Mass: 1.8kg

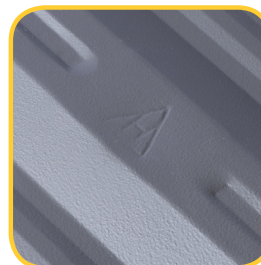

Harvey Elite

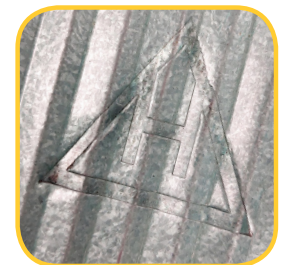

Harvey Thatch

The Harvey Quality Stamp

Beware of inferior imitations.

We take great care to ensure that every Harveytile is manufactured to the most stringent quality standards. As a division of Africa's leading steel supplier, Macsteel, we have access to the best steel. We prepare and press the Zinc or Alu-Zinc coated steel to the finest tolerances, cover the tile with natural stone coatings and finally achieve the tile with the best appearance.

Once complete, we take care to quality check each tile so as to ensure that it meets our quality standards. Only then do we place our Harvey Quality Stamp on each tile.

This means you can rest assured that if the tile carries the Harveytile Quality Stamp, that it's a Harveytile manufactured to the most exacting standards. Look for the Harveytile Quality Stamp.

"If it doesn't say Harveytile, its not a Harveytile"





Protecting the Environment. Protecting your home.

Mineral Polymer Composite Roof Tiles

Lightweight, strong and beautiful roof tiles

Harvey EcoTile® is an innovative roofing solution crafted from 97% waste materials, setting a new standard for sustainable construction. Combining strength, beauty and eco-conscious design, these Mineral Polymer Composite Roof Tiles are transforming the industry, one roof at a time.

What Makes Harvey EcoTile® Unique?

Made from a cutting-edge blend of recycled polyolefin and waste minerals, EcoTile® offers a host of advantages:

Shatterproof and Resilient

With strength levels four times greater than traditional concrete tiles, EcoTile® eliminates concerns about brittleness.

A Lighter Load

Weighing 70% less than comparable concrete tiles, these lightweight tiles simplify installation without sacrificing durability. The reduced weight greatly reduces transport costs and the need for costly weight bearing roof trusses.

Strength Meets Style

Harvey EcoTile® is engineered for exceptional performance. Its innovative material composition and precise fixing methodology create a roof that's virtually impenetrable to weather. The result? Symmetrical, seamless lines that deliver superior weatherproofing and eliminate gaps, ensuring your roof is not only water- and dust-proof but also visually stunning.



Solar Bracket

- Stylish Double Roman design combines exceptional functional advantages with classic aesthetics.
- Advanced engineering provides a system for weather proofing and superior strength.
- Precision-fit accessories provides weatherproof, maintenance-free seal.
- Non-porous, non-brittle finish ensures low water absorption and light weight in all weather conditions.



Future-Proof Roofing



Lightweight

- 70% lighter than comparable concrete tiles
- Save on roof-structure timber costs
- Transport 3 times more roof tiles with one load
- Easy offload and handling on-site



Low Maintenance

- UV stability
- Ridge Tile assembly does not require unsightly cement and debris
- No need to repaint your roof
- Will not shift due to fixing methodology



Strong & Durable

- 4x stronger than standard concrete tiles
- Virtually unbreakable in normal use
- Shatterproof
- Walkable once installed
- Enhanced security
- Non-brittle
- Save up to 10% on breakages vs. concrete tiles



Weatherproof

- Precision engineered design
- Gaps are eliminated
- Wind proof beyond gale force
- Hail proof
- Water and leakproof
- Minimised dust ingress
- Low water absorption



Attractive design

- Classic Double Roman design
- Creates a precise and uniform complete structure
- Consistent matte black textured surface
- Through-colour (not coated)



Easy installation

- 5 Location points for ease of placement
- Fixing screw ensures quick fastening and suitable for high wind areas
- On-site speed due to light weight
- "Cuts like butter" with no dust unlike concrete tiles



Paintable

- Standard matte marbled charcoal coloured tile
- No need to paint
- Paintable with Harvey Products approved paint in any colour desired post construction



SANS 10400-T Tested

- Harvey Eco Tile is tested in Accordance to SANS -10177 - 123 and conforms to SANS 10400-T with regards to safety distance
- Agrément certification ref: 2021/624



Solar Compatible

- Fixing brackets available
- A masonry drill bit can easily be used for drilling holes for wiring / piping requirements



Re-roofing

- Suitable for re-roofing over an existing roof
- No disruption to occupants, tenants or business activity



Waste Material

- Manufactured from mineral waste products
- Each tile removes the equivalent of 3.8 two-litre milk bottles from the environment



100% Recyclable

- Harvey EcoTile® is manufactured from 100% recyclable waste material



Waterless Production

- No water is required in the manufacturing of Harvey EcoTile®
- Zero water content in finished product



Community Development

- Materials are sourced from local community projects
- Production stimulates primary and secondary job creation

Technical Specifications

Tile weight (ave): 1.6kg each
Tiles per m²: 9.6
Weight per m²: 15.36kg

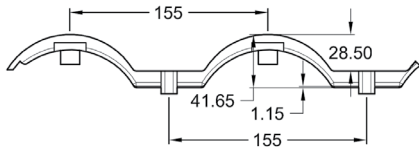

Wall thickness: 4.5mm
 Overall thickness: 12mm

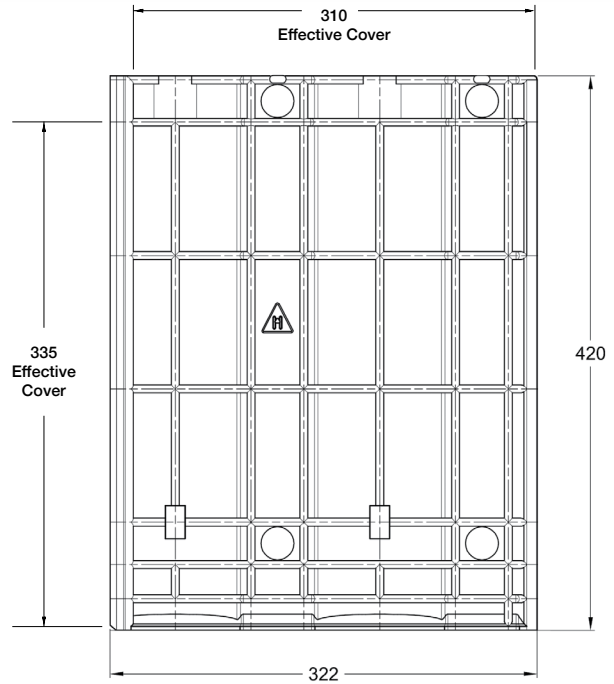

Accessories

Ridge Cap

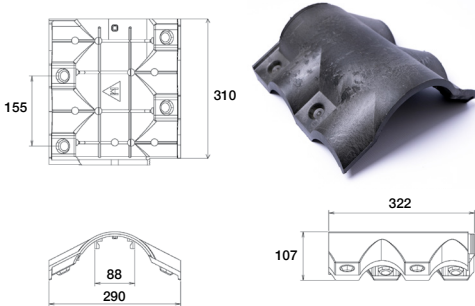

Weight: 1.6kg each

Hip Cap

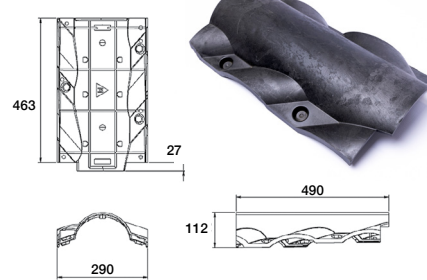

Hip Starter

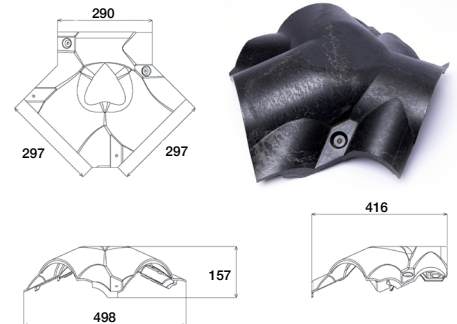

Weight: 1.6kg each

Hip End Cap

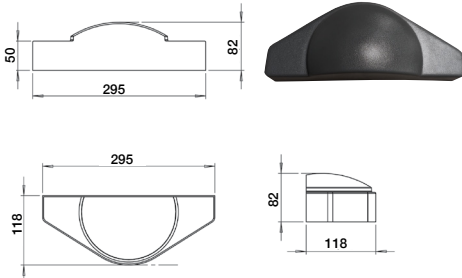

Fastening Accessories

Self Drilling screw #10 (4.8mm) x 45mm Hex Washer Head T17 CL3 + #10 x 16mm Bonded Washer with Seal



5/16" A.F. Hex black colour cap; HDPE UV stabilized; 16mm flange

Solar Bracket



Harvey Roofing Products

A Division of Macsteel Service Centres SA (Pty) Ltd.
 Tel: +27 11 741 5600
 info@harveyroofingproducts.co.za
 www.harveyroofingproducts.co.za

